

# LINEAR

# Ac0610



MOTOR FREE  
PISTON SYSTEM



### Airflow & Power Consumption

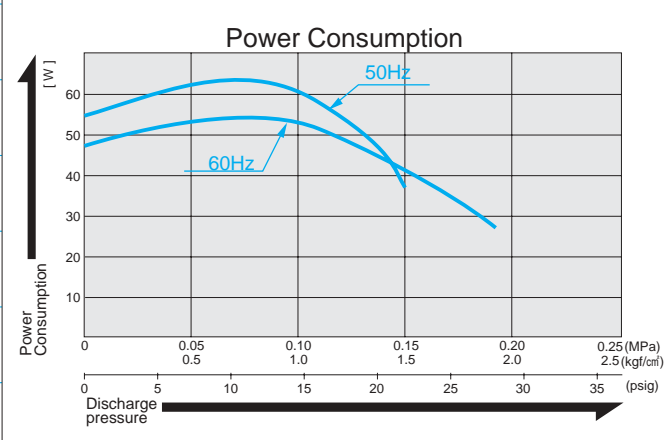
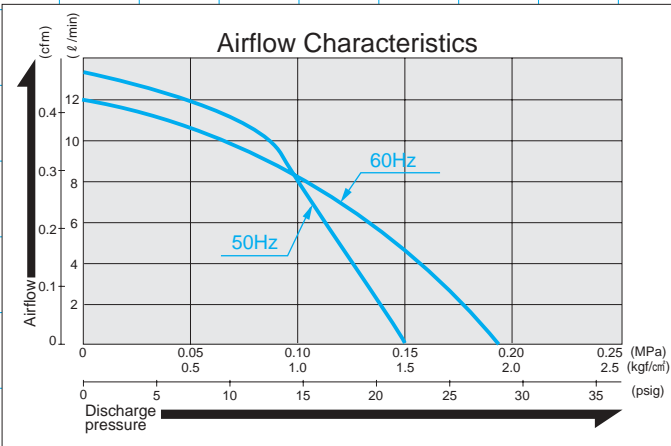

### Specifications

	(SI)	(EURO)	(U.S.A.)
Rated Pressure	0.1 MPa (1.0 kgf/cm <sup>2</sup> )	1.0 bar	14.2 psig
Rated Airflow	8 l /min		0.28 cfm
Rated Voltage	115 V, AC or 230 V, AC		
Maximum Pressure	0.15 MPa (1.5 kgf/cm <sup>2</sup> )	1.5 bar	21.3 psig
Power Consumption	52 W or 60 W		
Rated Frequency	60 Hz or 50 Hz		
Life Expectancy	3,000 hours		
Outlet	ISO Rc 1/4 (female threaded)		
Duty Cycle	Continuous		
Coil Insulation Class	E or its equivalent (JETL) and B for UL		
Mounting Dimensions	68 (L) x 84 (W) mm		
Gross Weight	3.2 kg	7.1 Lbs.	
Leadwire Length	270 mm or 200 mm	7-7/8" for 115 V	

\* Life expectancy is the expected accumulated period of time during which the compressor will maintain the above specifications. Contact your supplier for details of the conditions of use under which the values and numbers stated herein are maintained.

### Application Examples

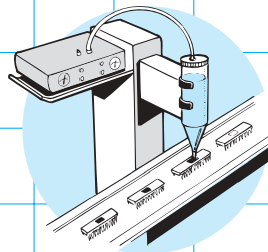

Dispenser

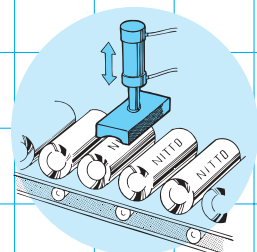

Automatic Stamper

### Sketch Drawing and Mounting Dimensions Diagram (mm)

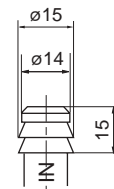
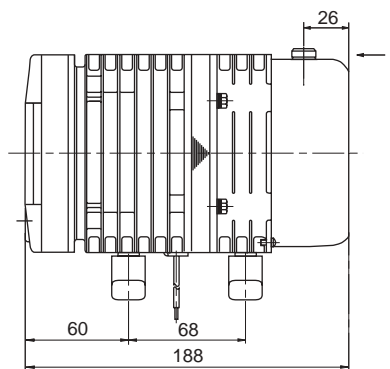
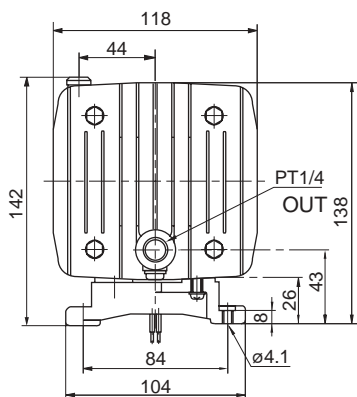

View A